



DODGE 06-08 1500 GRILLE GUARD

PART NUMBER : 110 300 0800

800-504-5684

info@bigdogbumpers.com
www.bigdogbumpers.com

TOOLS NEEDED : 19MM SOCKET OR WRENCH
14MM SOCKET AND WRENCH

**** REQUIRES CUTTING OR REMOVAL OF AIR DAM ****



1. Take 1 of the large "L" brackets and hold flush to the outside of the frame, just behind the radiator support. By holding flush to the frame, this will show you where you need to notch the air dam. Repeat on other side.
2. Cut a 1/2 in. notch in air dam to allow "L" bracket to fit thru. SEE PICTURE # 1
3. Mount box channel bracket, from inside of frame, match 4 - pattern with wide end of "L" bracket. Thread with 3/8 in. hardware provided. Hand tighten for now. These brackets should be flush with the back of the radiator support, and "L" bracket passing thru air dam. SEE PICTURES # 2 & # 3
4. On backside of factory bumper, remove factory nut from bottom outside frame flat bracket. Place lower support bracket over bolt, and rethread factory nut. Insert 1 1/2 in. bolt thru "L" bracket and lower support bracket. Hand tighten for now. SEE PICTURE # 4
5. Open hood, and remove the 2 inside top factory nuts from factory bumper bracket. SEE PICTURE # 5 Install 1 flat washer, then thread spacer coupling onto factory bolt. Tighten with 19mm socket.
6. Take 1in. Bolt (provided) and place 2 flat washers on it, insert thru triangular end of upper support bracket, thread into spacer coupling. Hand tighten for now. Repeat on other side. SEE PICTURE # 6
7. Lift new Big Dog grille guard up to "L" bracket, matching up 3 - hole pattern. ("L" brackets should go to the inside of the grill guard frame)
8. Insert carriage bolts into 3 hole pattern, from outside to inside, thread flange nuts . Hand tighten for now.
9. Secure upper support bracket to inside of grille guard frame by, inserting carriage bolt from outside of grille guard to inside of upper support bracket, thread flange nut. Hand tighten for now. SEE PICTURE # 7
10. Level grille guard, with equal spacing between wings and outside of fenders. Tighten all bolts to 70 lbs. of torque.



PICTURE # 4



PICTURE # 5



PICTURE # 6



PICTURE # 7

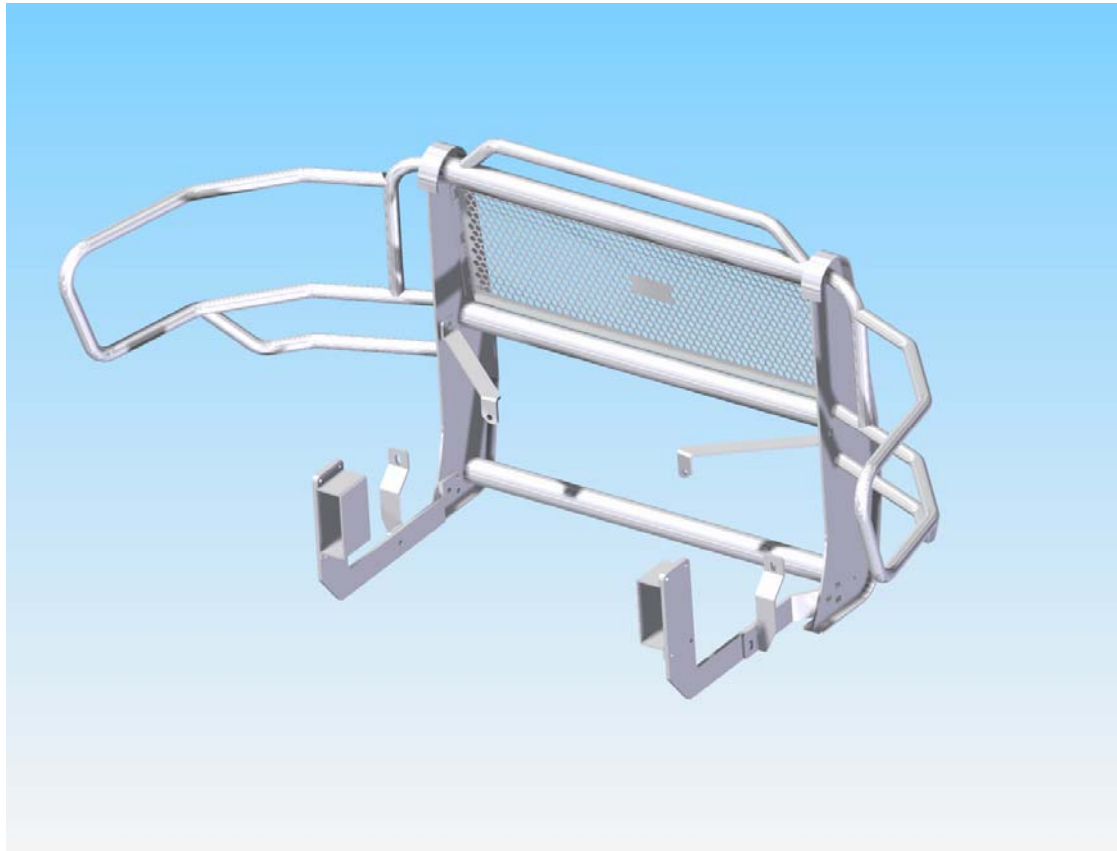

HARDWARE PROVIDED : 8 - 3/8IN. BOLTS 8 - 3/8IN. LOCKWASHERS
 8 - FLAT WASHERS 8 - 3/8IN. NUTS 16 - 3/8IN. FLAT WASHERS
 2 - SPACER COUPLINGS 8 - 1 1/2 IN. CARRIAGE BOLTS
 2 - 1 1/2 IN. BOLTS 2- 1IN. BOLTS 10 - FLANGE NUTS

